

SEMI-AUTOMATIC STRETCH WRAP MACHINE - SWA-50

APPROX WEIGHT: 542.73 lbs.
DOES NOT INCLUDE WEIGHT OF POWER OR PACKAGING!!!

*** ANY ADDITIONS, DELETIONS, OR OMISSIONS MUST BE CORRECTED ON THIS DRAWING AS THIS DRAWING WILL BE CONSIDERED ALL INCLUSIVE ***

ALL GRAPHICS PROVIDED ARE FOR REFERENCE ONLY. IF CERTAIN DIMENSIONS ARE CRITICAL PLEASE VERIFY THOSE DIMENSIONS WITH YOUR SALESPERSON

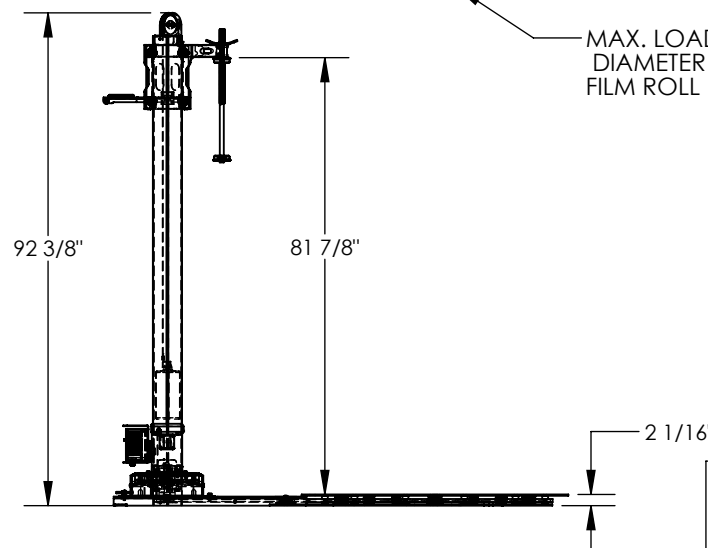
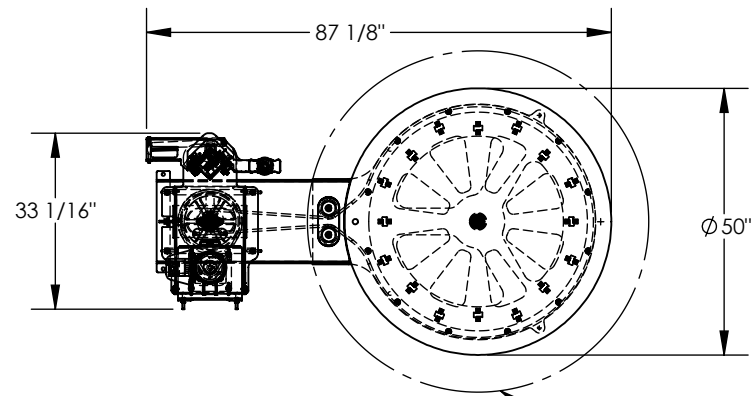

EYE BOLT USED FOR LIFTING ONLY. IT MUST BE REMOVED FOR MACHINE OPERATION

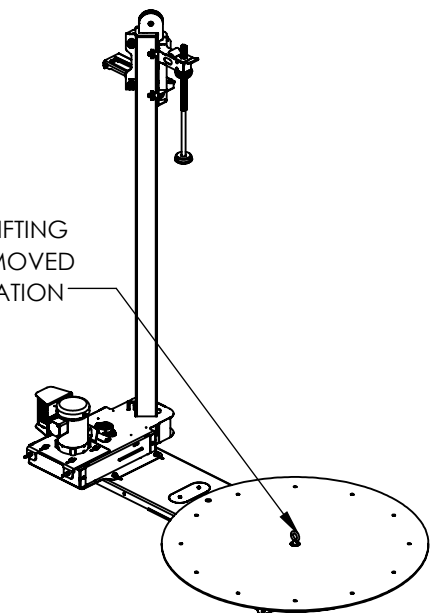

3-D VIEW FOR REFERENCE

MAX. LOAD CLEARANCE DIAMETER 64" INCLUDES FILM ROLL DIAMETER

THE USE OF A GFCI WILL REQUIRE THE USE OF A LINE-REACTOR CONSULT YOUR LOCAL ELECTRICAL SUPPLIER FOR DETAILS

DIMENSION TOLERANCE $\pm 1/4"$

STANDARD FEATURES

- MODEL NUMBER: SWA-50
- CAPACITY: 4000 LBS.
- TURN TABLE DIAMETER: 50"
- OVERALL LENGTH: 87 1/8"
- OVERALL HEIGHT: 92 3/8"
- MAX WRAP HEIGHT: 81 7/8"
- TURN TABLE DECK HEIGHT: 2 1/16"
- POWER INPUT: 115 V 1-PHASE
- BELT DRIVEN
- VARIABLE SPEED TURN TABLE (3-12 RPM)
- WITH SOFT START/STOP
- FOOT CONTROL FOR TURN TABLE ROTATION
- DECK IS TOUGH BAKED IN POWDER COATED YELLOW FINISH
- FRAME IS TOUGH BAKED IN POWDER COATED BLUE FINISH

SPECIAL FEATURES

NONE

APPROVAL

I, THE UNDERSIGNED, AGREE THAT THE PRODUCT AS REPRESENTED SATISFIES DESIGN AND DIMENSION REQUIREMENTS. I ALSO ACKNOWLEDGE MY DUTY TO CONFIRM PRODUCT AND INSTALLATION COMPLIANCE WITH ALL APPLICABLE FEDERAL, STATE AND LOCAL REGULATIONS AND STANDARDS.

UNITS REQUIRING APPROVAL DRAWINGS OR MODIFIED ARE NON-RETURNABLE

[] As drawn [] As marked

Signed: _____ Date: _____

Printed Name: _____

LEAD TIME WILL START UPON RECEIPT OF SIGNED APPROVAL DRAWING

DISTRIBUTOR'S NAME:		P.O.#
VESTIL MANUFACTURING		X
DRAWN BY: SJA		W.O.#
DATE: 11/26/2014		X
REFERENCE: X	SCALE: 1:36	SALES: X
QUOTED LEAD TIME: X	QUOTE #	FILE NAME:
	X	20-007-116